

.812-16 UNF 3A
 Minimum 8 Threads
 Major Dia. 0.8125 / 0.8080
 Pitch Dia. 0.7584 / 0.7543
 Minor Dia. 0.7123 / 0.7143

0.0005 A

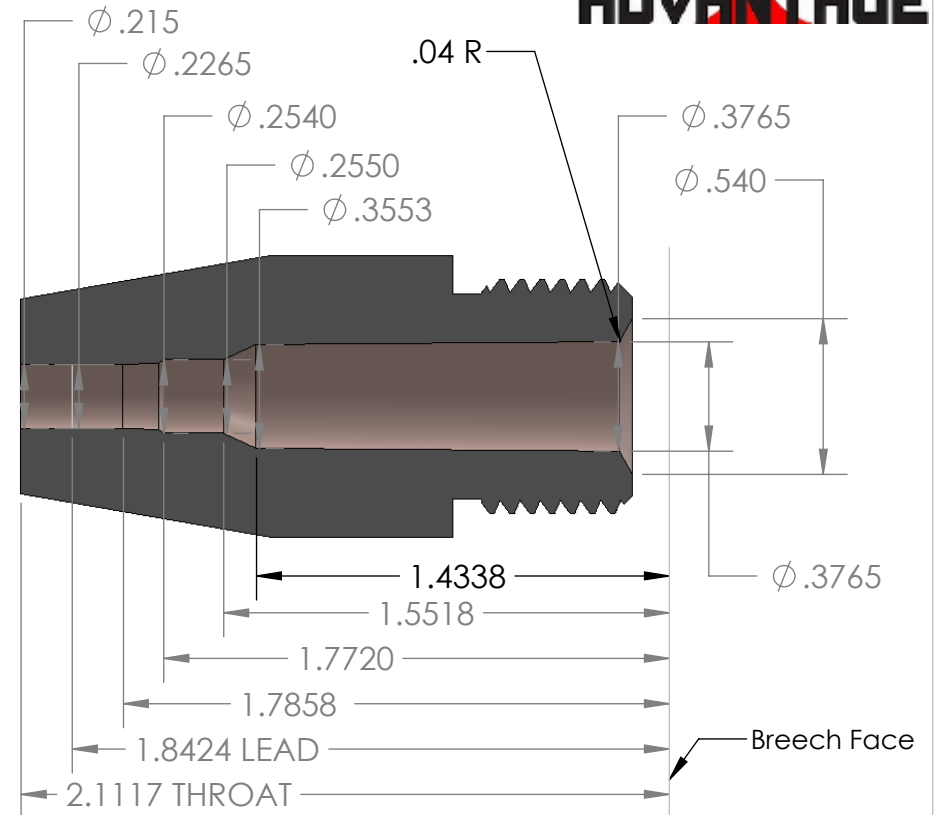

Standard Tolerances		UNLESS OTHERWISE SPECIFIED:	NAME	DATE	Ballistic Advantage		
X.XXXX	0.0005	DIMENSIONS ARE IN INCHES TOLERANCES: FRACTIONAL ± ANGULAR: MACH ± BEND ± TWO PLACE DECIMAL ± THREE PLACE DECIMAL ±	DRAWN		TITLE:		
X.XXX	0.002		CHECKED		5.56 NATO Chamber		
X.XX	0.01		ENG APPR.				
		INTERPRET GEOMETRIC TOLERANCING PER:	Q.A.		SIZE	DWG. NO.	REV
		MATERIAL	COMMENTS:		A	556 NATO Chamber	
		FINISH			SCALE: 1:1	WEIGHT:	SHEET 1 OF 1
NEXT ASSY	USED ON	APPLICATION	DO NOT SCALE DRAWING				

PROPRIETARY AND CONFIDENTIAL
 THE INFORMATION CONTAINED IN THIS DRAWING IS THE SOLE PROPERTY OF Ballistic Advantage. ANY REPRODUCTION IN PART OR AS A WHOLE WITHOUT THE WRITTEN PERMISSION OF Ballistic Advantage IS PROHIBITED.